

Pixel Octo

ETHERNET PIXEL DRIVER

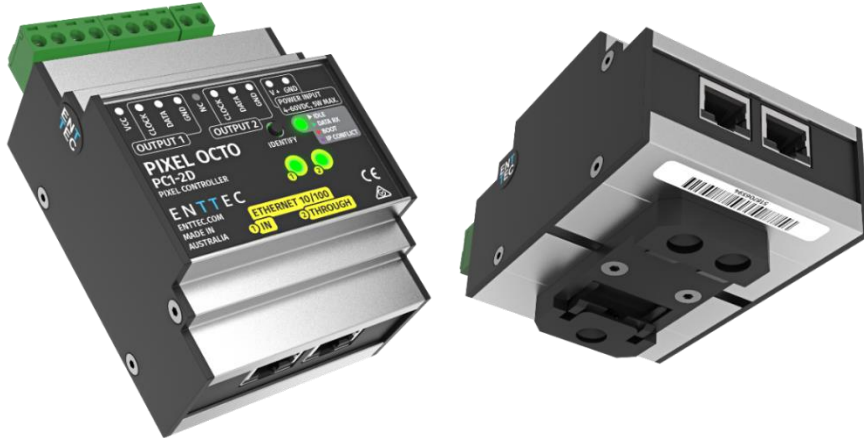

Contents

Package Contents	1	DMX Start Address.....	7
Safety Information	1	Standalone.....	7
LED Protocols Supported.....	1	Show Options – Activate Standalone Show.....	8
Physical Dimensions.....	1	Creating a Standalone Show	8
Functional Features	2	Deleting a Standalone.....	10
Hardware Features.....	2	Copying a Standalone Show.....	11
LED Status.....	2	Importing and Exporting a Standalone List.....	11
Status.....	2	Network Stats.....	11
Link 1 and Link 2.....	2	Art-Net and ESP	11
Identify Button	2	sACN.....	11
Wiring Diagrams.....	3	KiNET.....	12
Default IP	4	Update Firmware.....	12
Finding the IP Address Using NMU.....	4	Reset to Factory Defaults.....	12
Web Configuration.....	5	Using Web Interface.....	12
Home.....	5	Using Button	13
Identify Button.....	5	Tips and Guidelines.....	13
Settings	6	Ordering Information.....	14
Direct.....	6	Specifications.....	14
DMX Protocols.....	6		
Universes/Outputs	7		
Group Pixels	7		

Package Contents

- Pixel Octo (71520)
- Read me card

Safety Information

- This unit is intended for indoor use only.
- Do not expose this device to rain or moisture, doing this will void the warranty.
- Make all connections before powering on
- Do not remove the cover, there are no user serviceable components inside.
- Never plug this unit into a dimmer pack
- Ensure input voltage is within the specified limits
- Ensure this device functions within the [recommended operating temperature](#)

LED Protocols Supported

- 9PDOT-8bit and 9PDOT-16bit
- TM1804, TM1812 and TM1814
- WS2811, WS2812, WS2812B, WS2813 and WS2815
- SK6812
- APA-104 and APA-102

Note:

We cannot claim to support all led protocols, but if you do happen to find one that does work, and is not listed, please let us know.

Physical Dimensions

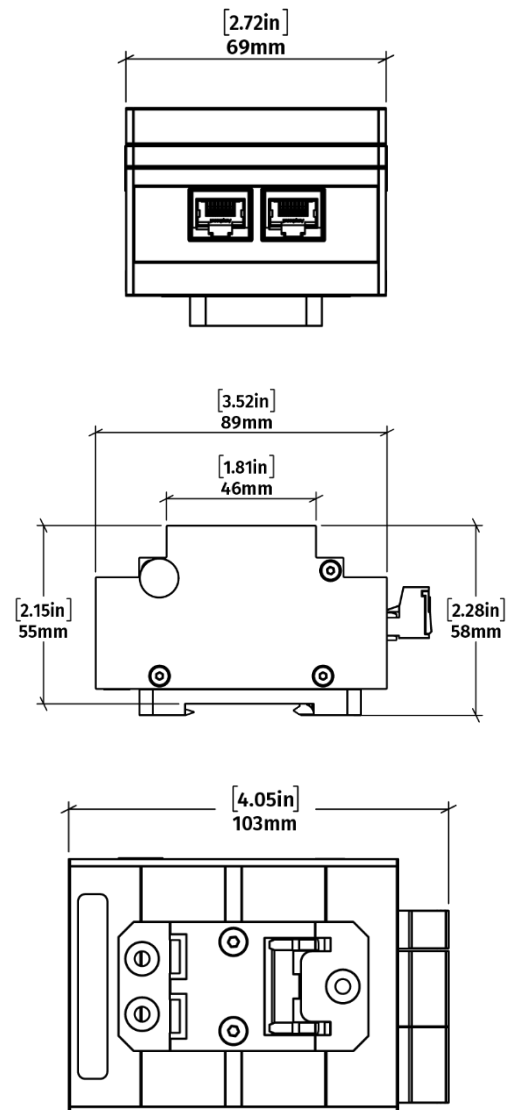

Functional Features

- Supports the following protocols:
 - Art-Net
 - Streaming ACN (sACN)
 - ESP
 - KiNET
- Configurable Static or Dynamic (DHCP) IP (DHCP by default).
- Web configurable
- Firmware updateable
- Netmask and gateway updateable
- Up to 8 ethernet universes support (maximum of 4 universes per output port)
- Controls a maximum of 680 RGB or 512 RGBW pixel LEDs (per output).
- Configurable pixel colour ordering
- Monitors device temperature
- Monitors and displays the network traffic
- Easily extendable network – daisy chain ethernet connection up to maximum of 50
- Compatible with CLK LED Tapes
- White Pixel Order support
- 35mm DIN mountable
- Flexible wiring configurations
- User-friendly interface to create and execute live effects on the fly
- Save created effects into a list of standalone shows

Hardware Features

- Aluminium Enclosure
- Top view indicator lights and button
- Pluggable terminal blocks
- Dual Spring 35mm DIN rail brackets

LED Status

Status

- This LED indicates the Pixel Octo status and should be constantly flashing.
- The current operating status of the LED is indicated as follows:

LED Colour	Unit Status
Red	Device in boot
White (static)	Idle
Purple (static)	IP Conflict
Green over white	Direct mode data receiving
Black over white	Standalone mode
Red over green	Multiple merge sources

Link 1 and Link 2

- These two LEDs indicate network status for each RJ45 port

Identify Button

The identify button serves 2 purposes:

- Identify the corresponding pixels connected to a specific Octo
- Reset Pixel Octo ([Refer Reset Pixel Octo](#))

When identify button is pressed, all DMX channels of the pixels connected at the output will be driven to the maximum value for ten seconds.

Wiring Diagrams

LEGEND

—	VCC
—	CLOCK (MAY NOT BE REQUIRED FOR SOME LED TAPES)
—	DATA
—	GROUND

POWER CONNECTION (POWER INPUT TERMINALS)

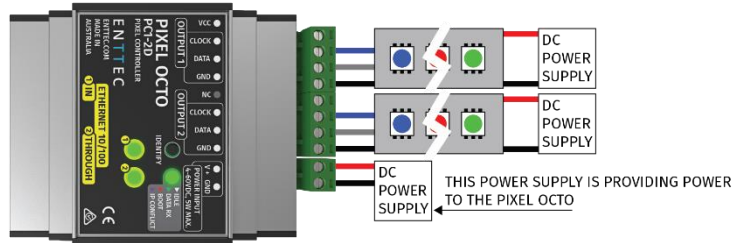

POWER CONNECTION (VCC TERMINAL)

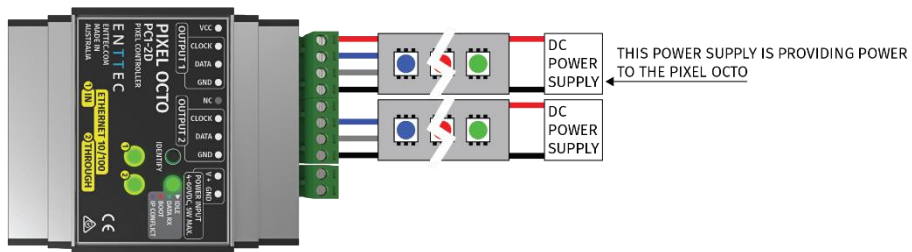

POWER CONNECTION (USING TERMINAL SPLITTERS)

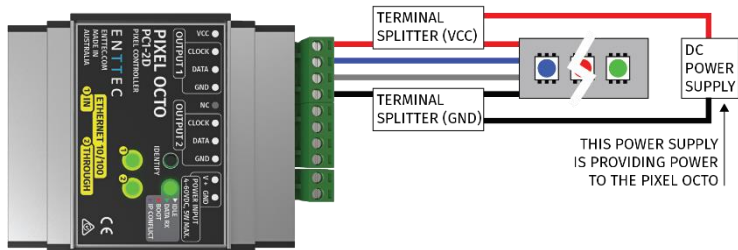

MULTIPLE LED POWER INJECTION

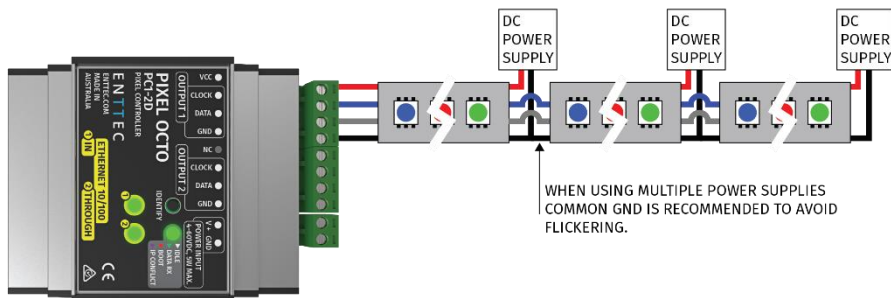

MULTIPLE LED TAPE SECTIONS

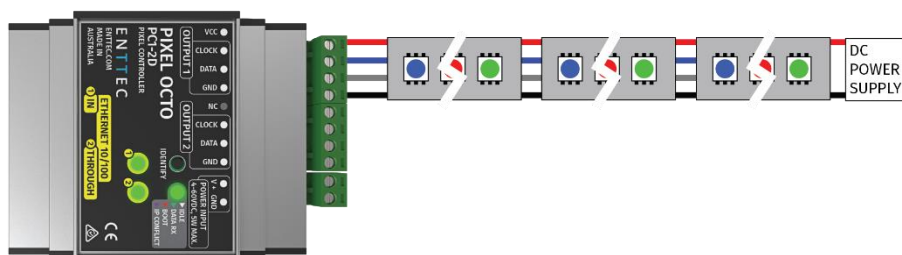

Default IP

Right out of the box, the Pixel Octo is factory configured to be a DHCP node, so you can plug it into your existing router, and it is good to go.

If the router is unable or slow to assign an IP address to the driver the default static IP Address is used.

The IP address can easily be calculated, using the MAC address as follows:

10.(byte1).(byte2).(byte3)

Note

Where byte1, byte2 and byte3 are the last three bytes of the mac address in decimal.

For e.g.:

- If mac address is 0050C2FFFF55 where last three bytes are FF, FF and 55 default static IP for the above mac is 10.255.255.85
- Where byte1 FF is 255 in decimal
- Where byte2 FF is 255 in decimal
- Where byte3 55 is 85 in decimal

The built-in web-interface of the Pixel Octo can be accessed using the IP address via any modern web-browser. The web-interface allows the settings of the unit to be changed.

Finding the IP Address Using NMU

ENTTEC provides a free App (available for Windows and Mac) called NMU (Node Management Utility) that finds the Pixel Octo and display its IP address.

Note:

Pixel Octo is only supported by NMU V1.92 and above.

Please follow these steps:

1. Download NMU from www.enttec.com
2. Pixel Octo should be connected physically by an Ethernet cable to the same physical network or router as the computer that is running NMU.
3. Open NMU. If prompted with multiple network interfaces, select the correct one to which the Pixel Octo is connected to
4. Press the Discovery button, and wait till NMU finds all supported ENTTEC devices

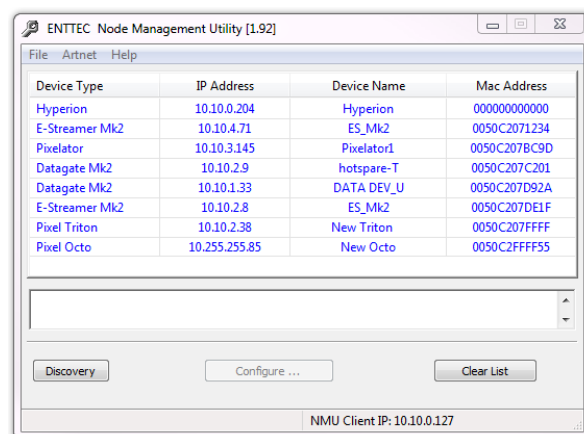

5. Once found, select Pixel Octo and use the IP address to access the web-interface

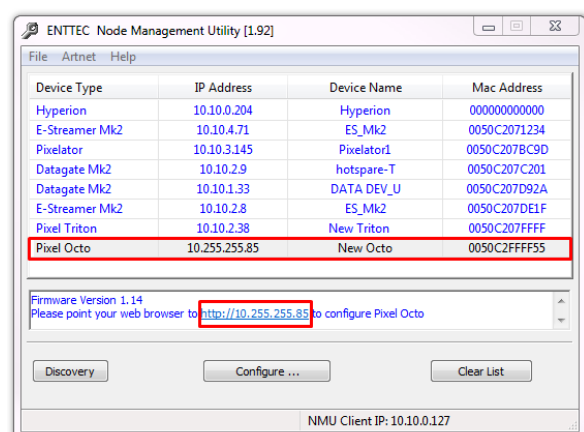

Web Configuration

The Pixel Octo can be configured and controlled through a web browser, running on a computer system, located on the same Local Area Network.

Note:

Google Chrome is recommended for accessing the Octo web interface

Either click on the underlined URL displayed in NMU or type the IP address (as detected by NMU e.g.: 10.255.255.85) into your web browser to access the web interface.

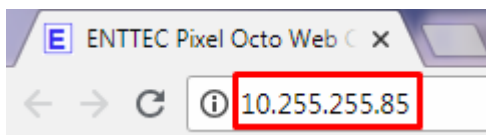

The top menu allows all the Pixel Octo web pages to be accessed.

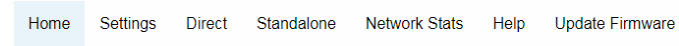

Menu option is highlighted blue to indicate which page the user is on.

The web interface shows the word Direct or Standalone depending on the mode the device is in, as shown in the images below



Home

The Home tab displays the following information:

- DHCP status – whether enabled
- IP address
- NetMask
- Gateway

- Mac Address
- Link Speed
- Device Name
- Firmware version on device
- Serial number of the device
- Internal temperature of the processor
- System uptime
- Input protocol set on device
- Output LED protocol set on device

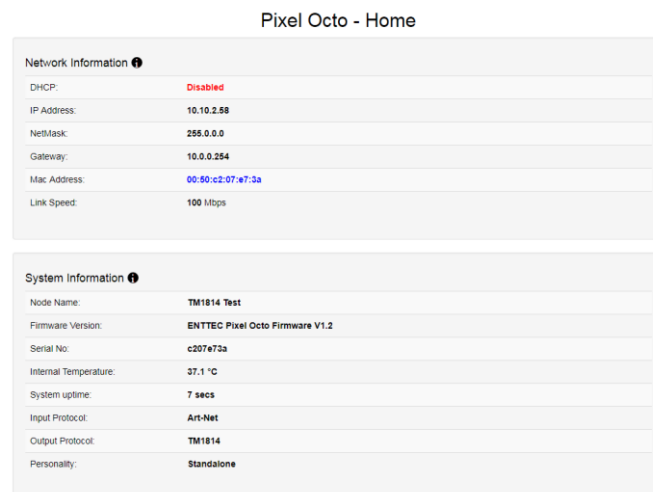

Identify Button

The identify button helps find the corresponding pixels connected to a specific Octo.

When identify button is pressed, all DMX channels of the pixels connected at the output will be driven to the maximum value for ten seconds. For example: an RGB tape will have all its channels go to full resulting in a white colour for ten seconds.

Once pressed, a 10 second timer is displayed

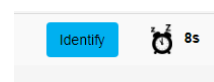

Note:

Timer will not restart when pressed consecutively

Settings

The screenshot shows the Settings page with three main sections:

- Network Information:** Includes fields for Node Name (Testing Octo), DHCP (Use DHCP checkbox), Static IP Address (10.10.255.238), Static NetMask (255.0.0.0), and Gateway IP (10.0.0.254).
- Output Settings:** Includes a dropdown for Led Protocol (Output), Pixel Order (Output1: GRB, Output2: GRB), and Mapped Pixels (Output1: 680, Output2: 680).
- Save & Update:** Includes buttons for Save Settings, Factory Default: Reset to Defaults, and Device Reboot: Reboot.

The Settings page allows a user to do the following:

- Change a device name for identification
- Enable/disable DHCP
- Specify static network settings
- Set the output LED Protocol
- Set the number of mapped pixels
- Configure how colours are mapped to pixels
- Reset to factory defaults
- Reboot device

Direct

Direct can be activated by clicking on the Use Direct mode button in the Direct page as shown in the image below

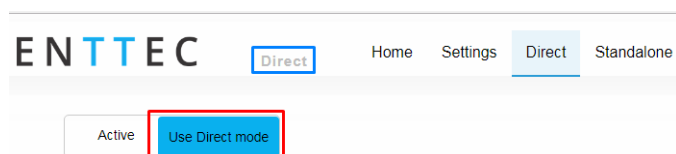

When activated, the word Direct will be displayed next to the ENTTEC logo as shown in the image.

DMX Protocols

KiNET

Supported commands:

- Discover device
- Discover ports on device
- Change device name
- Change device IP
- Portout commands
- DMX out commands
- KGet Command
 - KGet Subnet Mask
 - KGet Gateway
 - KGet port universe (port 1 and 2)
- KSet commands
 - KSet Subnet Mask
 - KSet Gateway
 - KSet port universe (port 1 and 2)
 - KSet device to boot

Art-NET

Supports Art-NET 1/2/3. Each output can be assigned a start universe in the range 0 to 32764 (when universe/output = 4).

sACN

Outputs can be assigned a start universe in the range 1-63996 (when universe/output = 4). 1 multicast universe is supported for sACN sync.

ESP

Outputs can be assigned a start universe in the range 0-252 (when universe/output = 4). More details of the ESP protocol can be found at www.enttec.com

Universes/Outputs

The Pixel Octo converts up to four universes of DMX over Ethernet to pixel data per output.

Both outputs can be specified to use the same universes, e.g. both outputs use universe 1,2,3 and 4.

Each output can also be specified to use its own individual group of universes, e.g. output 1 uses universes 100,101,102 and 103 however output 2 uses 1,2,3 and 4.

Only the first universe can be specified; the remaining universes, second, third and fourth are automatically assigned subsequent universes to the first one.

Example 1:

If the first universe is assigned 25, the second, third and fourth universes will be automatically assigned 26, 27 and 28 as shown in the image below.

Pixel Mapping Options ⓘ	
Output1	
Universes/Outputs:	4
First Universe:	9
Second Universe:	10
Third Universe:	11
Fourth Universe:	12

Group Pixels

Controls the number of pixels controlled by each DMX channel.

Example:

When group pixel is set to 10, each DMX channel of the universe will control 10 pixels. The maximum pixels lit is determined by mapped pixels; this parameter can take a maximum of 680 (RGB) or 512 (RGBW).

DMX Start Address

Selects DMX channel number, which controls the first pixel. When the universes/output is more than one, the DMX start address only applies to the first universes. However, where it applies, a start address offset may result in the split of a pixel. E.g R channel in first universe and GB channels in the seconds universe for a RGB LED.

For ease of pixel mapping we recommend offsetting the DMX start address as follows:

- Increments of 3 for RGB (1,4,7, 10)
- Increments of 4 for RGBW (1,5,9,13)
- Increments of 6 for RGB-16 bit (1,7,13,19)
- Increments of 8 for RGBW-16 bits (1,9,17,25)

Standalone

Standalone can be activated by clicking on the Use Standalone mode button as shown below

ENTTEC Standalone Home Settings Direct Standalone

Activate Use Standalone mode

Show Options ⓘ

Output 1:

Output 2:

Save Settings

When activated, the word Standalone will be displayed next to the ENTTEC logo. When operating in this mode note the following:

- 9PDOT-16bit protocol is not supported
- RGBW tapes are supported but white cannot be controlled.

Show Options – Activate Standalone Show

Octo allows the control of the standalone show played at each of the two outputs. This is controlled by the Show Options section. Both can be set to output no standalone show:

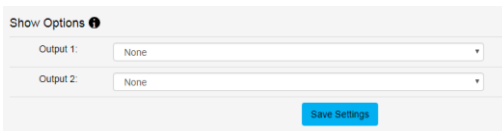

The outputs can play the same standalone show concurrently:

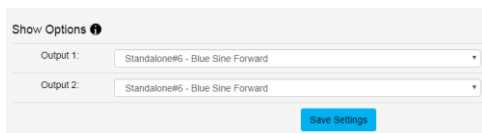

Or each can be set to output a different show:

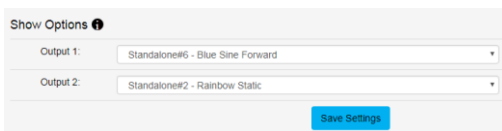

Creating a Standalone Show

A standalone show can only be created when Standalone mode is activated. Please follow these steps to create a standalone (effect):

1. Select the next available standalone slot and click on Create button

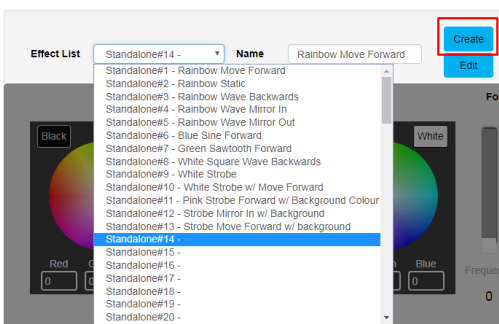

2. Select an output to preview the standalone show on by using the check boxes

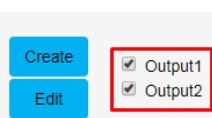

3. If the effect previewed is to be preserved, Type in a name and click on Save Effect button

Preview Standalone

Pixel Octo allows the preview of the standalone. Select the output to preview the standalone as shown in the previous image.

If two different colour orders e.g.: RGB on output 1 and WWA in output 2 are assigned you can only preview the effect on one output at a time. If you attempt to preview both outputs the following message is displayed

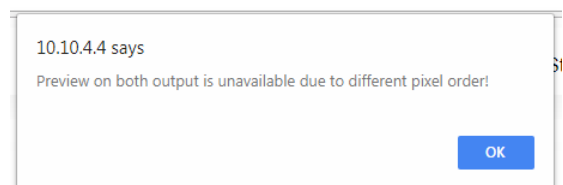

Standalone Show Name

Up to 65 characters can be used for a standalone show name. All characters are supported except comma (,). Octo does not allow a standalone to be saved with an existing name on the list

Standalone Layers Explained

When creating a standalone the light output should be visualized as two layers:

- Background (controls shown in red)
- Foreground (controls shown in blue)

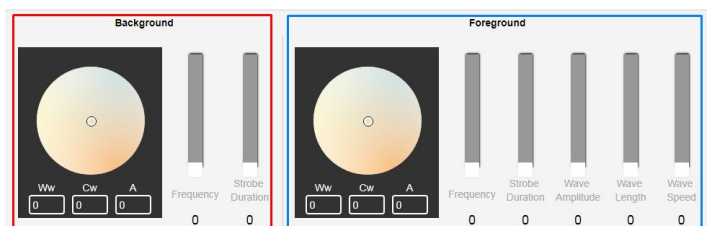
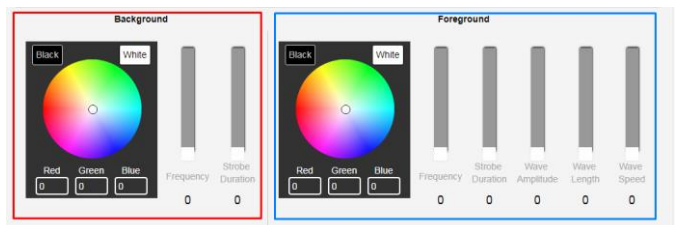

Pixel Octo also has colour wheel support for WWA (warm white, cool white and Amber) pixel tape

Background

By only enabling the background layer the Pixel tape/dots will respond like a standard RGB tape.

The background can be:

- Set to a constant colour
- Dimmed
- Made to strobe

The controllers affect the entire length up to the maximum possible pixels (e.g. 680 3-channel pixels)

Foreground

This layer creates effects that overlay on the background colour. The foreground can be:

- Set to a constant colour
- Dimmed
- Made to strobe
- Set to create patterns

Master Intensity

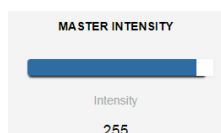

Controls the overall brightness of the output (both for foreground and background). Where:

- 0 – no LEDs are switched on
- 255 – LEDs on are at full brightness

Background/Foreground Strobe Frequency

Controls the time between LED(s) on and off time.

- 0 – LEDs switch on and off at slowest speed
- 255 – LEDs switch on and off at fastest speed

Background/Foreground Strobe Duration

Controls the time that the LEDs are on

DMX fader value	On time
0	Always on
1	Smallest duration
255	Longest duration

Wave function

The foreground layer can be controlled to form patterns of the following wave functions:

- Sine wave
- Log wave
- Square wave
- Sawtooth wave
- Rainbow Sine Wave
- Rainbow Log Wave
- Rainbow Square Wave
- Rainbow Sawtooth

Wave Direction

The wave pattern can be set to travel. Wave direction setting determines which way the pattern will travel. The wave can be set to move:

- Forward
- Backward
- Mirror out – pattern travelling out of centre
- Mirror in – pattern travelling into centre

Wave Amplitude

This setting determines the brightness of each pixel in a period of the wave.

DMX fader value	Brightness of Pixels in One Wave Period
0	Vary between 50% and full
255	Vary between off and full on.

Wave Length

This setting determines the number of pixels in one period of the wave.

DMX fader value	Wavelength
0-1	2 pixels
2-255	Fader Value

Wave Speed

This setting controls the speed at which the wave pattern travels across tape.

DMX fader value	Speed
0	Minimum speed
255	Maximum speed

Offset

Offset allows the pattern on a port to be delayed.

Editing a Standalone Show

Octo allows the editing of any saved standalone. Please follow these steps to edit a standalone:

1. Select the standalone to be edited and click on Edit button

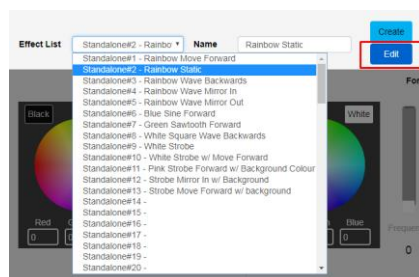

2. Select an output to preview the standalone on by using the check boxes

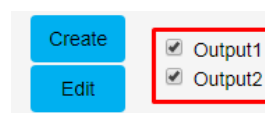

4. Edit the standalone
5. If the standalone previewed is to be preserved, click on Save Effect button

Deleting a Standalone

Select the standalone to be deleted and press on Delete button

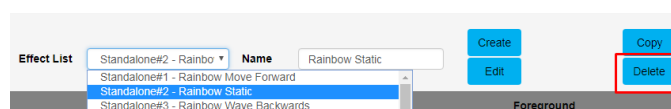

The standalone selected for each output will continue to play unless it is deleted; in this case, the standalone directly above will be enabled at the output, which had the deleted show. If there is no standalone above, no standalone will be output.

If a slot without a standalone is deleted the following message is displayed:



Copying a Standalone Show

Octo allows the copying of any saved standalone. Please follow these steps to copy a standalone.

1. Select the standalone show to be copied and click on Copy button

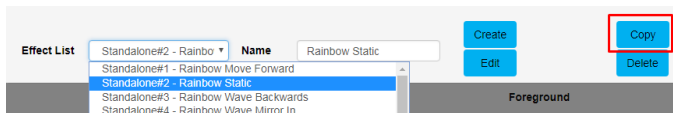

2. Provide a new name for the copied standalone

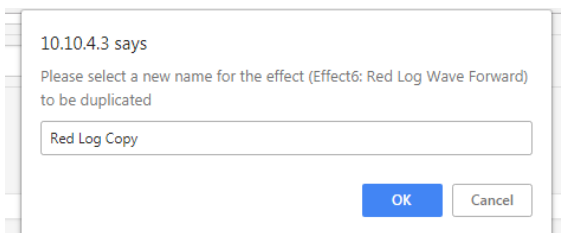

Note:

Octo does not permit two or more standalone shows with the same name

Importing and Exporting a Standalone List

Octo allows the import and export of all the standalone shows on the device.

Note:

The export file will include a list of all the standalone shows

Please click on Export Effect button to export the standalone shows

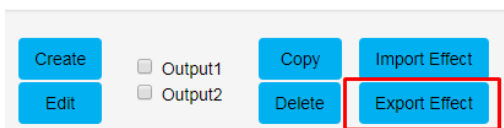

Please click on Import Effect button to import the standalone shows

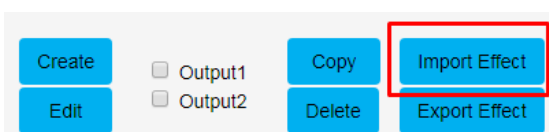

Network Stats

The Network page shows statistics for the DMX protocol enabled.

Art-Net and ESP

Network Protocol: Art-Net ⓘ	
Poll Packets Received:	0
Data Packets Received:	0
Last IP:	0.0.0.0
Last Port:	0
Refresh	

Network Protocol: ESP ⓘ	
Poll Packets Received:	150
Data Packets Received:	708
Last IP:	10.10.3.3
Last Port:	6454
Refresh	

The information provided is:

- Poll packets received
- Data packets received
- Last IP poll packets were received from
- Last port data received from

sACN

Network Protocol: sACN ⓘ	
Data Packets Received:	106
Sync Packets Received:	86
Last IP:	10.10.0.39
Last Port:	5568
Refresh	

The information provided is:

- Data and sync packets received
- Last IP packets were received from
- Last port data received from

KiNET

Network Protocol: KiNET ⓘ	
Total packets received:	2701
Discover Supply packets received:	2
Discover Ports packets received:	2
DMXOUT packets received:	0
KTYPE_GET packets received:	0
KTYPE_SET packets received:	0
PORTOUT packets received:	2685
PORTOUT Sync packets received:	10
Set ID packets received:	1
Set IP Address packets received:	1
Set Universe packets received:	0
Last IP:	10.10.0.127
Last Port:	65379

[Refresh](#)

The information provided is:

- Total packets received
- Discover supply packets received
- Discover ports packets received
- DMXOUT packets
- KGet packets
- KSet packets
- PORTOUT Packets
- Set device name packet received
- Set device IP packet received
- Set universe packets received
- Last IP received from
- Last port data received from

Update Firmware

It is strongly recommended that Pixel Octo is updated with the latest firmware, available on the ENTTEC website. This firmware can be loaded to the driver through its web interface by carrying out the following steps:

1. Browse and select the correct firmware version on your PC

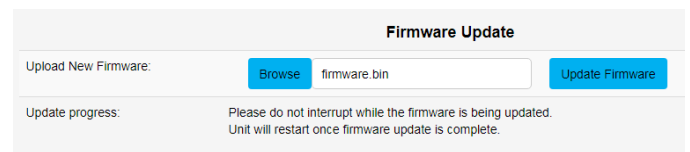

2. Press the Update Firmware button

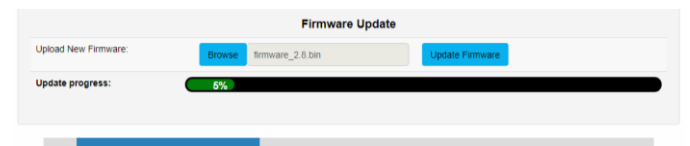

Once the firmware update is complete, the device will reboot while the web interface displays the message shown in the image below

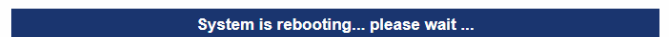

Reset to Factory Defaults

Using Web Interface

The reset to defaults command can be found under the Settings tab of the Pixel Octo.

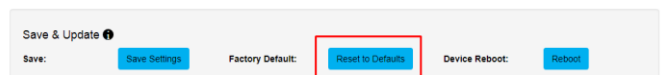

Once the command is pressed, a pop-up would appear as shown in the image below:

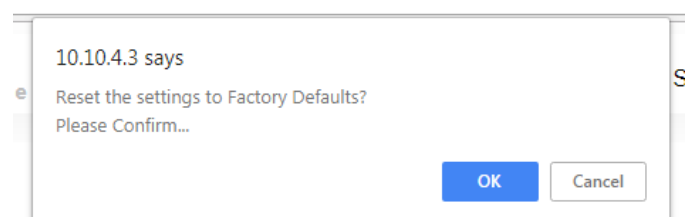

This operation:

- Resets the device name
- Resets the netmask
- Enables DHCP
- Resets IP Address (IP address = 10.(byte1).(byte2).(byte3) where the three bytes are the last three bytes of the mac address in decimal)
- Resets gateway
- Restores standalone shows to factory default.
- Direct mode is activated
- DMX protocol is made Art-NET
- LED protocol is set as WS2812B
- Pixel colour is set to RGB
- Both ports are set to output 4 universes. The start universe for output 1 is set as 0 and output 2 as 4
- Mapped pixels value is set to 680 pixels
- DMX start address is set to 0
- APA-102 global intensity set to maximum

Using Button

The reset button restores the network configuration of the Pixel Octo to factory defaults:

- DHCP is enabled
- Static IP Address reset (IP address = 10.(byte1).(byte2).(byte3) where the three bytes are the last three bytes of the mac address in decimal)

- Netmask is set to 255.0.0.0

To reset to factory defaults, the following procedure must be performed:

- Power off the unit
- Press and hold the Reset button.
- While holding the Reset button, power up the unit, and keep holding the button for 3 seconds.
- Release the Reset button once the status led starts blinking red.

Tips and Guidelines

Unable to open Pixel Octo web-page:

You must ensure that the Pixel Octo and your computer are on the same **subnet**

To troubleshoot:

1. Give your computer a Static IP address (e.g.: **10.0.0.1**)
2. Change computer Netmask to (**255.0.0.0**)
3. Please connect the Pixel Octo directly using a cat5 cable to your computer
4. Select the correct network on NMU (10.0.0.1)
5. If you have multiple networks (wifi etc.), please try to disable all other networks except the one Pixel Octo is connected to.
6. Once NMU finds the Pixel Octo, you will be able to open the device web-page and configure it
7. Reset the device if following the above steps did not resolve the issue

Can you run tapes and dots at the same time?

No, only one LED protocol can be selected to drive the output at a given time

What is the minimum DC voltage for powering Pixel Octo?

The minimum DC voltage is 4V

Ordering Information

Part Number	Description
71520	Pixel Octo

Specifications

Item	Specification	
Input Voltage	4-60V DC	
Maximum Power consumed	5W	
Supported Protocols	Art-Net	sACN
	KiNET	ESP
Output Protocols	WS2811	WS2812
	WS2812B	WS2813
	SK6812	TM1804
	TM1812	APA-104
	APA-102	9PDOT (8 – 16bit)
Maximum Pixel count/output (RGBW)	512 RGBW pixels	
Maximum Pixel count/ output (RGB)	680 RGB pixels	
Maximum footprint/output DMX	2048 channels	
Connectors	2 x 4Pin Output phoenix	
	1 X 2Pin Power In	
	2 X RJ45	
IP Rating	IP 20	
Operating Temperature	-10 °C to 60 °C	
Relative Humidity	5- 95% (non-condensing)	
Weight of device (In kg)	0.25 kg	
Dimensions (in mm)	103 (L) x 69 (W) x 58 (H)	

Due to continuous improvements and innovations of all ENTTEC products, specifications and features are subject to change without notice.

enttec.com

MELBOURNE AUS / LONDON UK / RALEIGH-DURHAM USA